

Please remove elements out of frame carefully.
It is recommended to use a blade at the cutline
to punch the element out of the sheet easier.

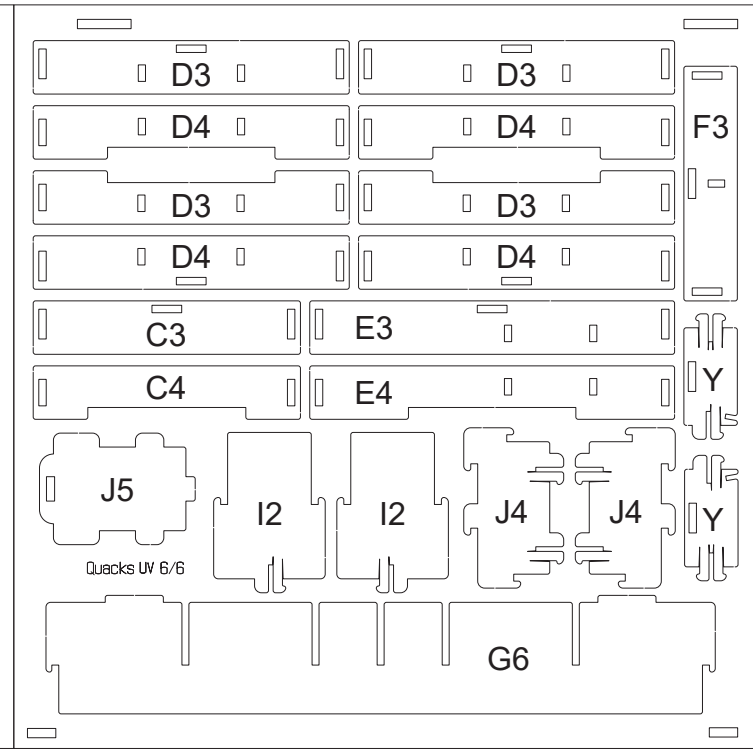

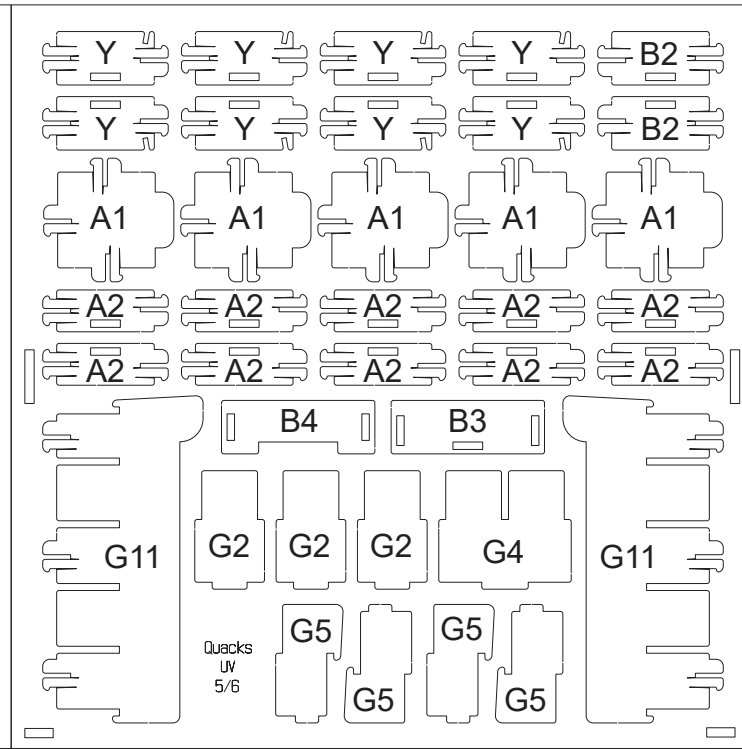

Alchemist's
Flasks

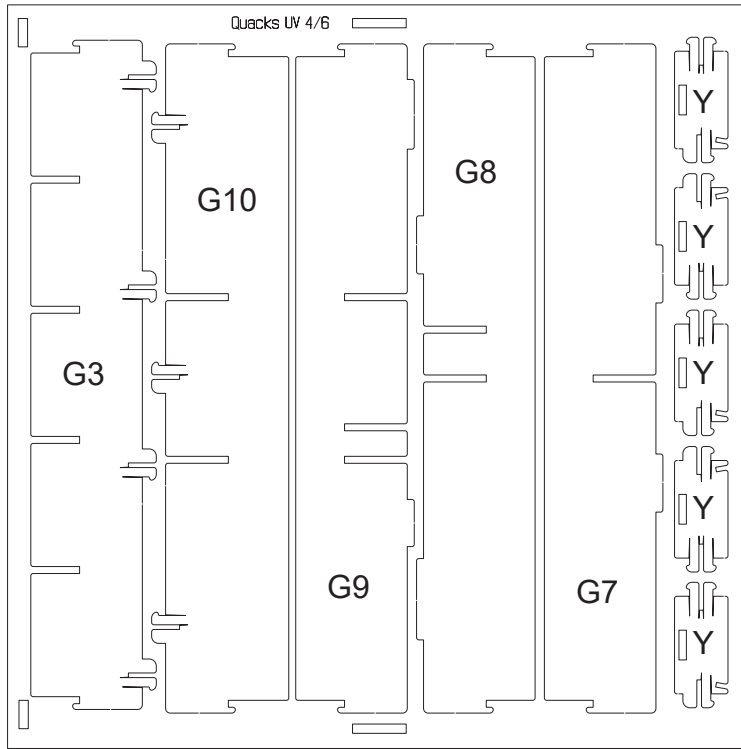
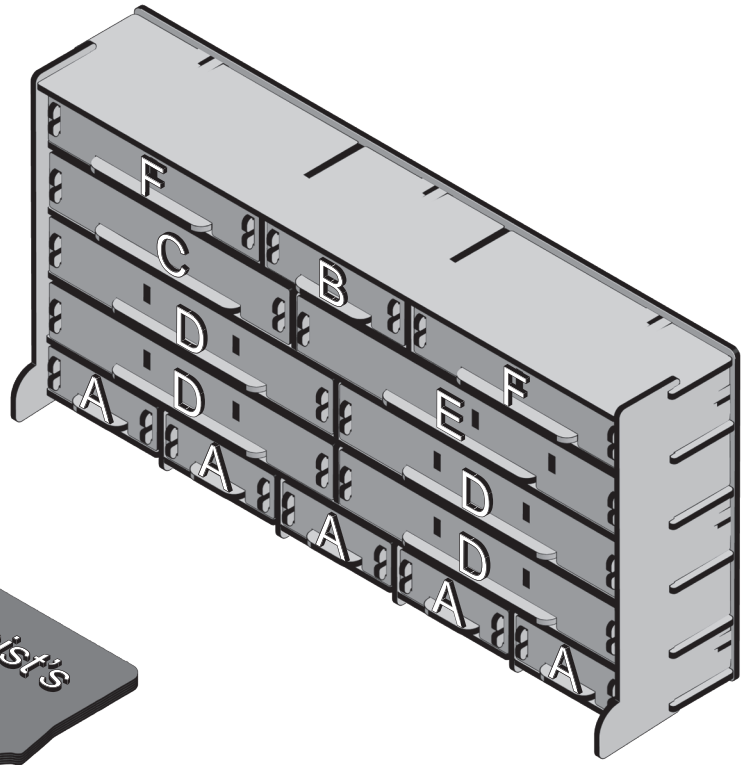
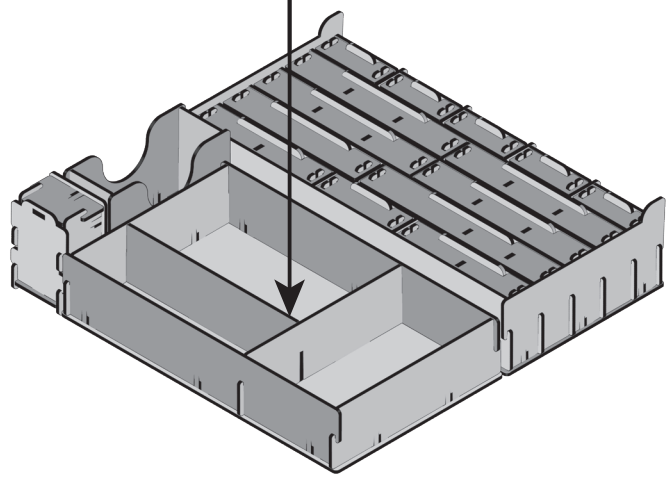

Scoring Track
and Rulebooks

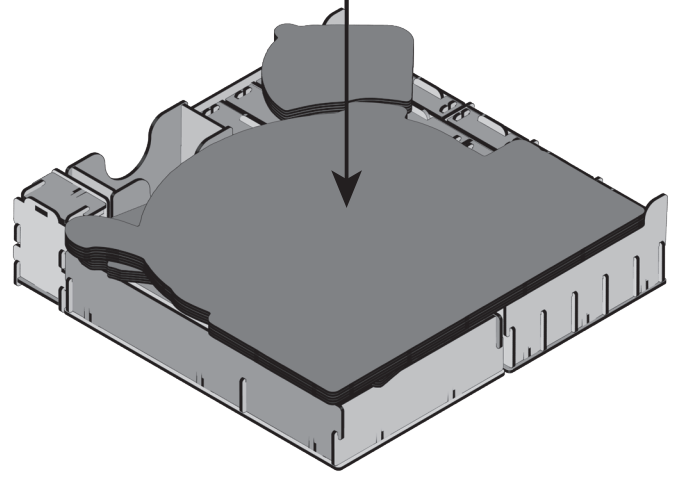

Bowls
Pots
(player boards)

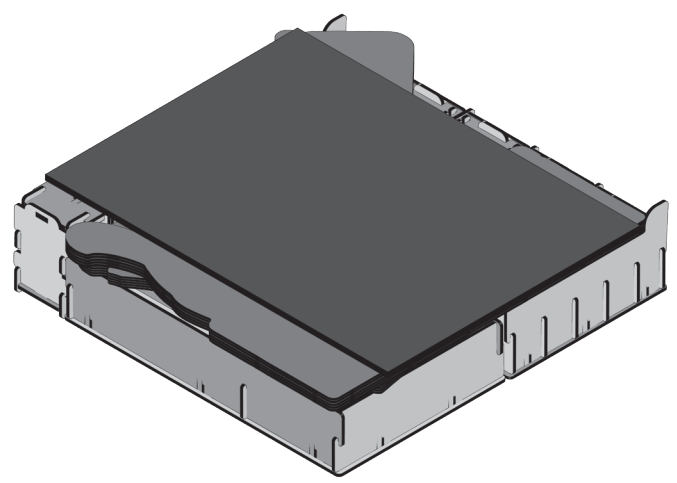
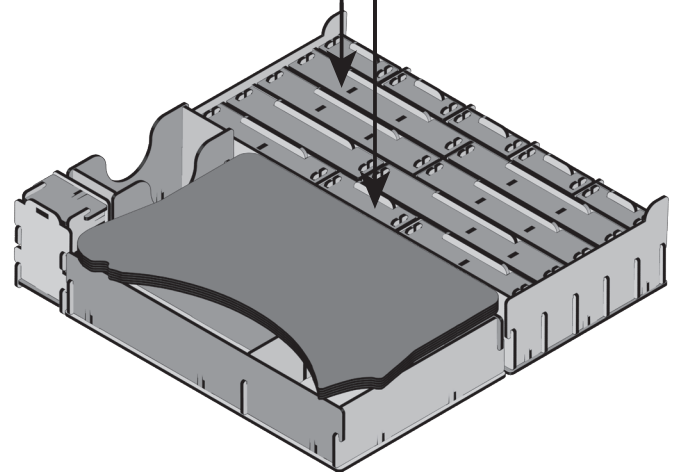

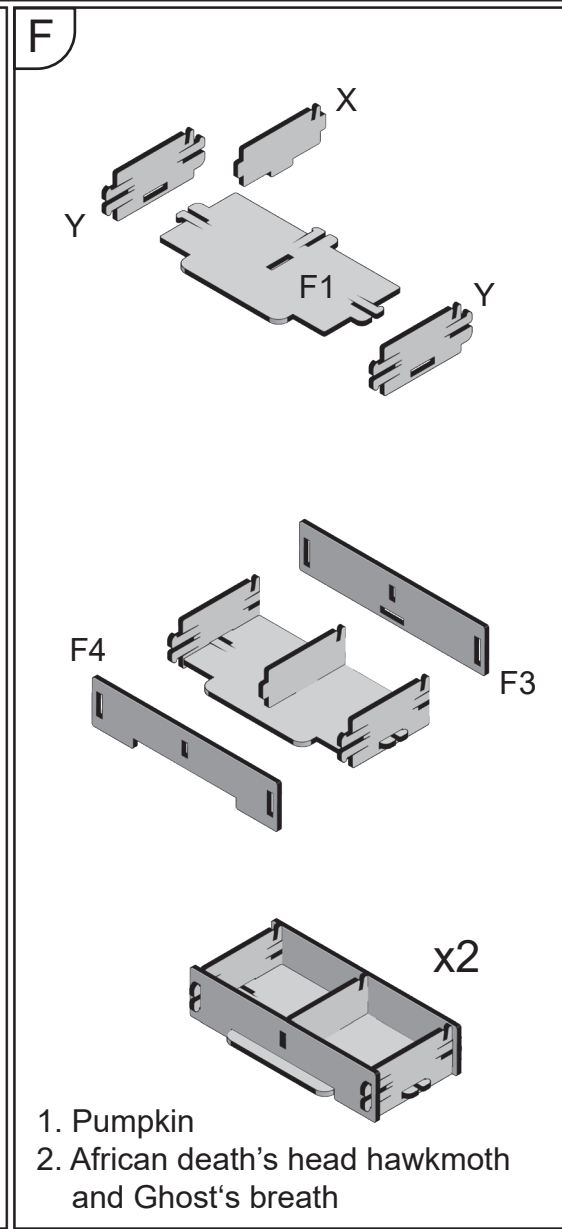
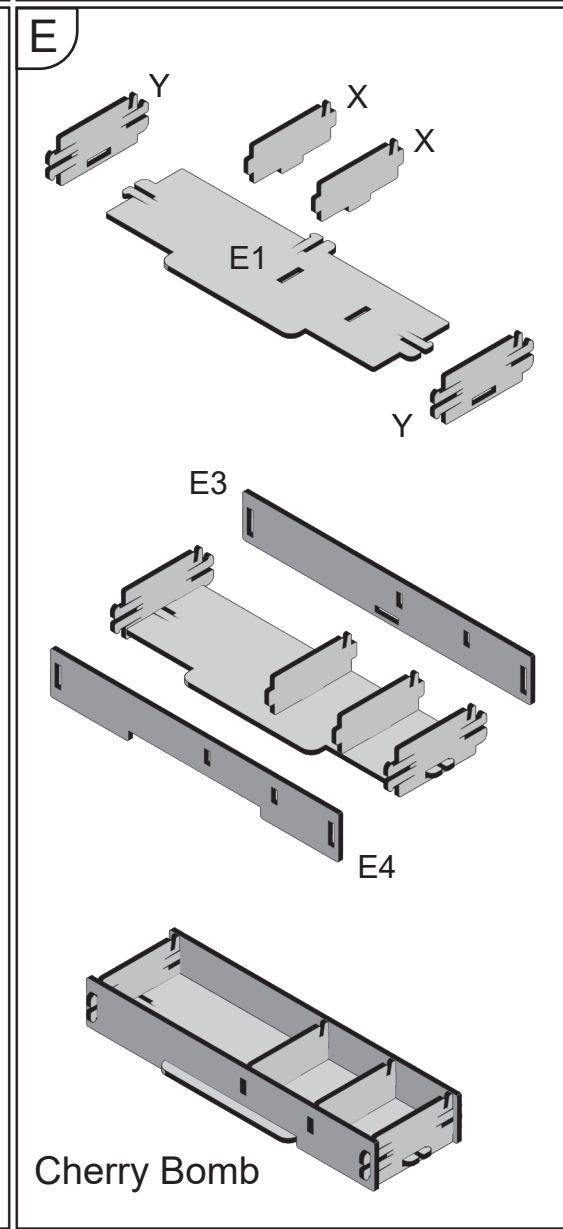
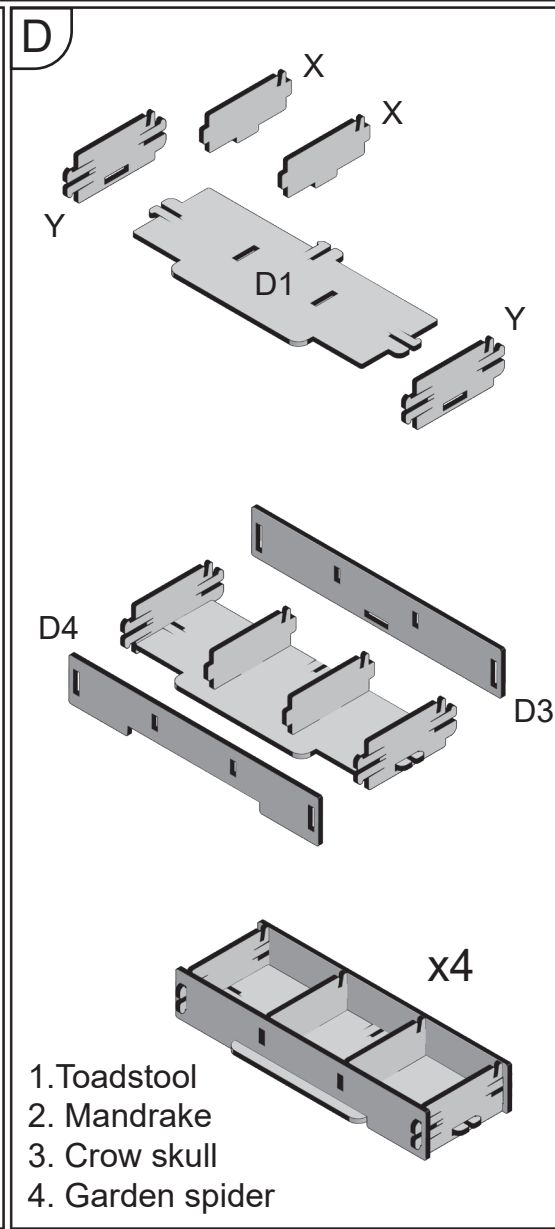
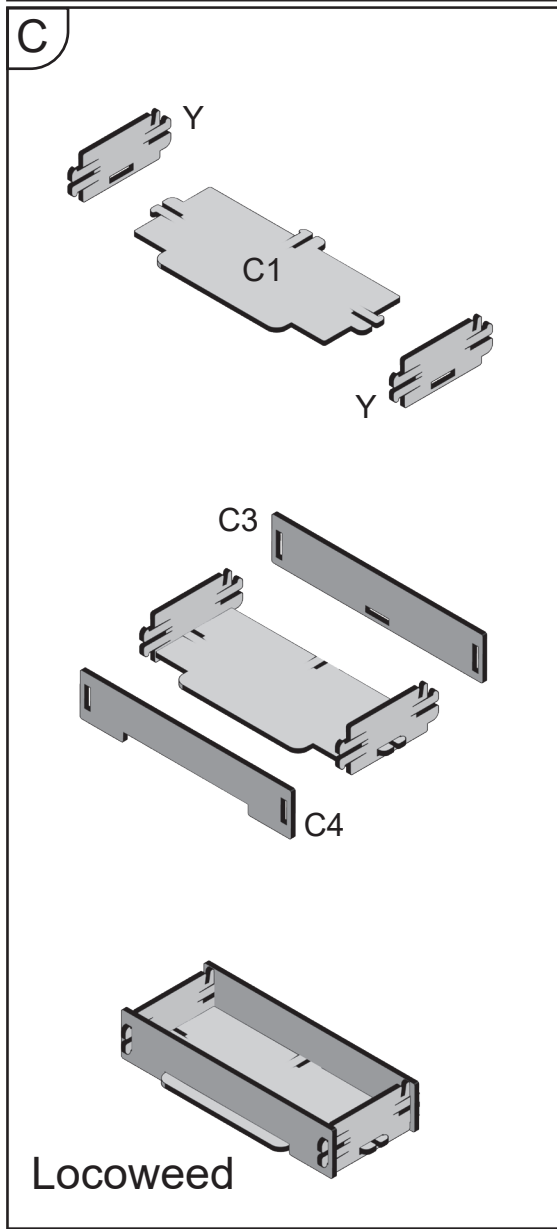
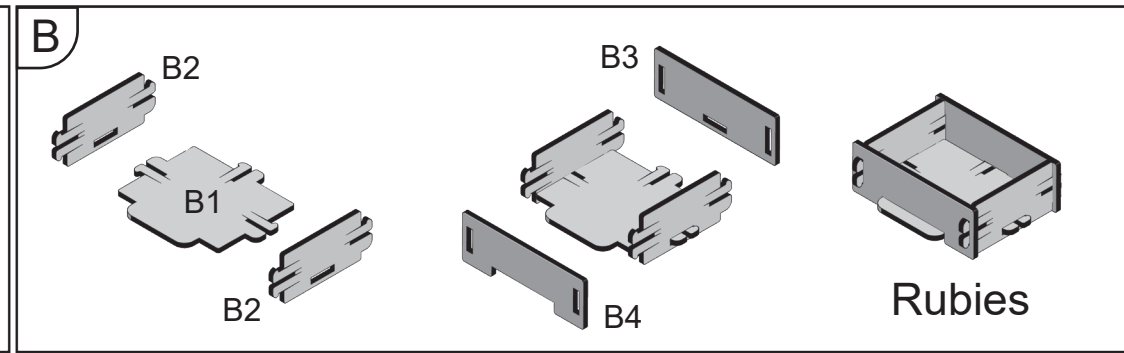
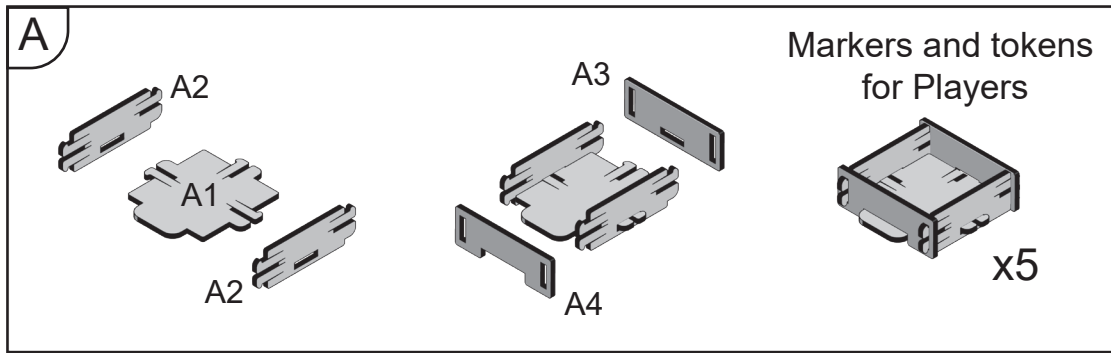

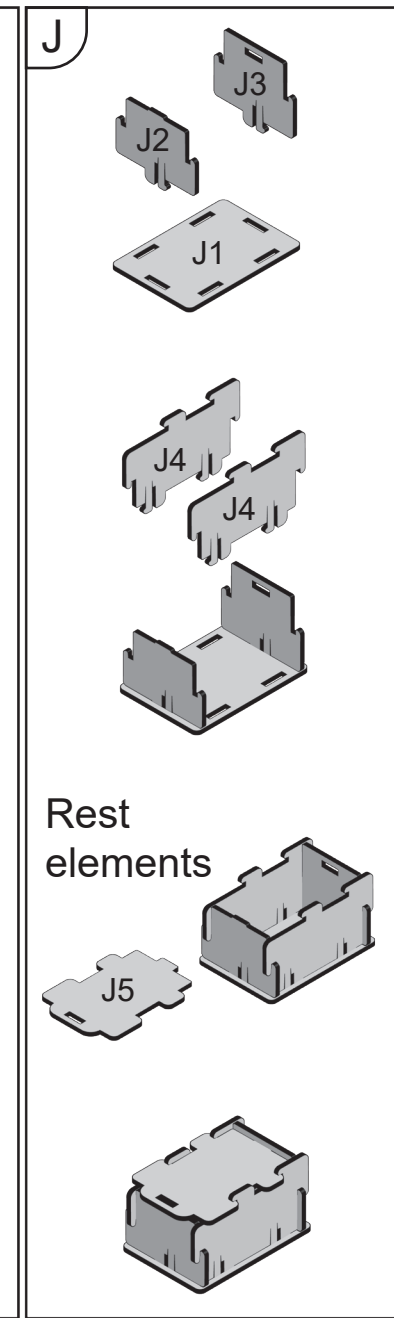
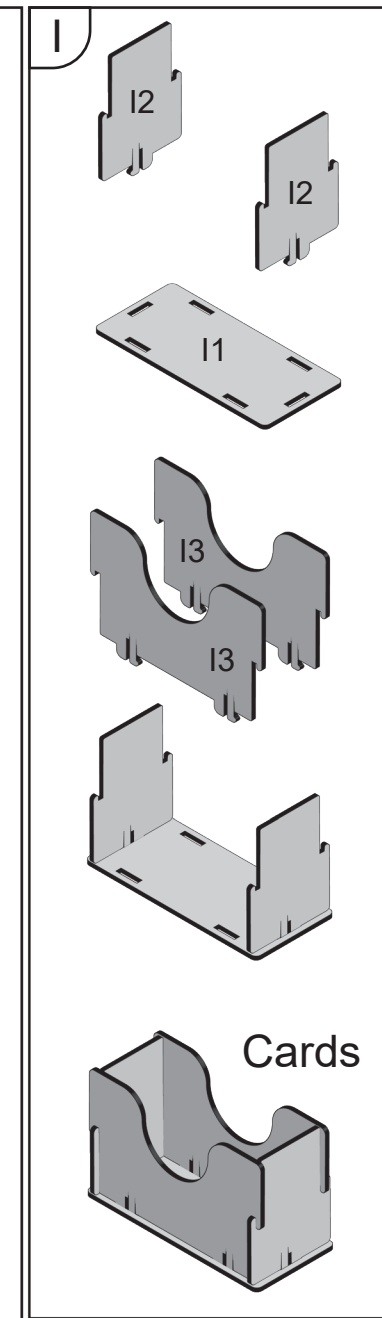
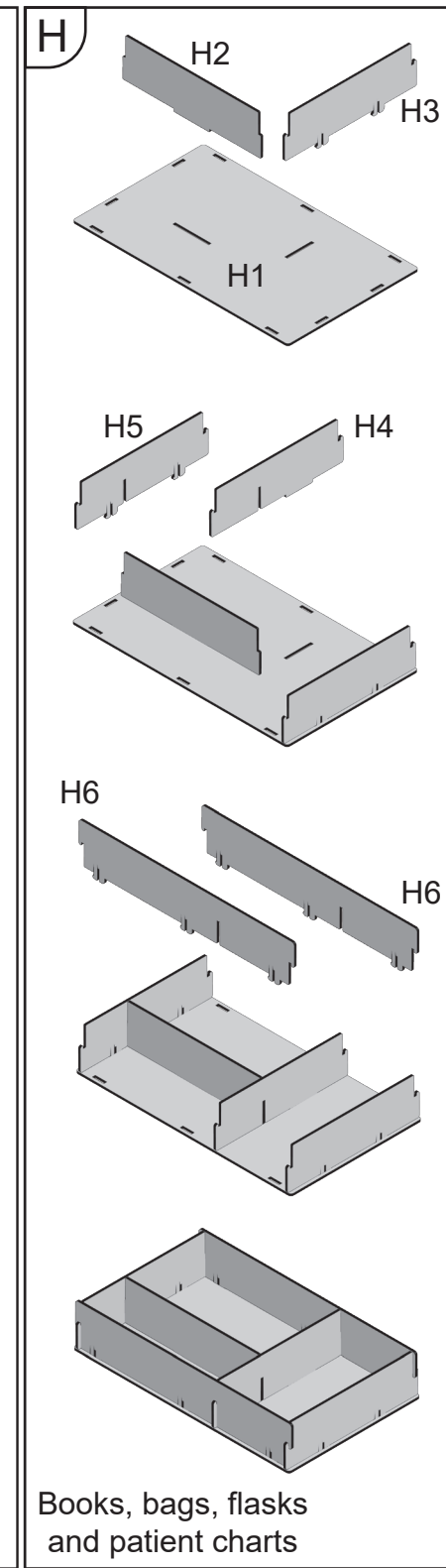
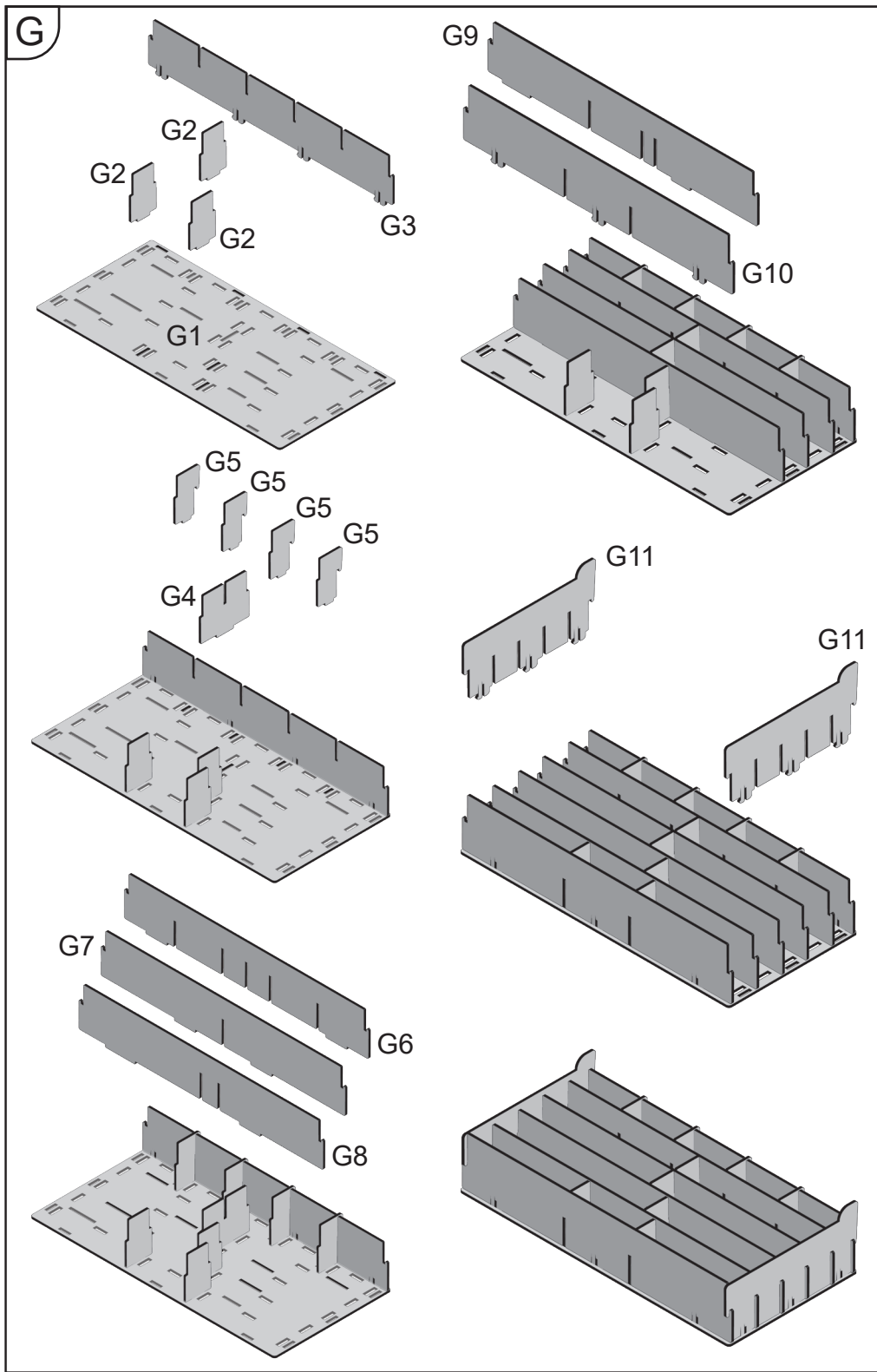

Books, bags, flasks and patient charts

Insert compatible with the game:
**The Quacks of Quedlinburg +
 The Alchemists + The Herb Witches expansions**

Please remove elements out of frame carefully.
 It is recommended to use a blade at the outline
 to punch the element out of the sheet easier.

Assemble based on element letter.
 Then from number first to last.